

大人の科学 Otona no Kagaku
The Sophisticated Science Kit for Adults

MECHAMO

メカモクラブ Mechamo Crab ●●●THEMECHANICALANIMALSERIES

Instructions for Assembling and Operating

The parts list is separately attached.



Crab
角牛虫

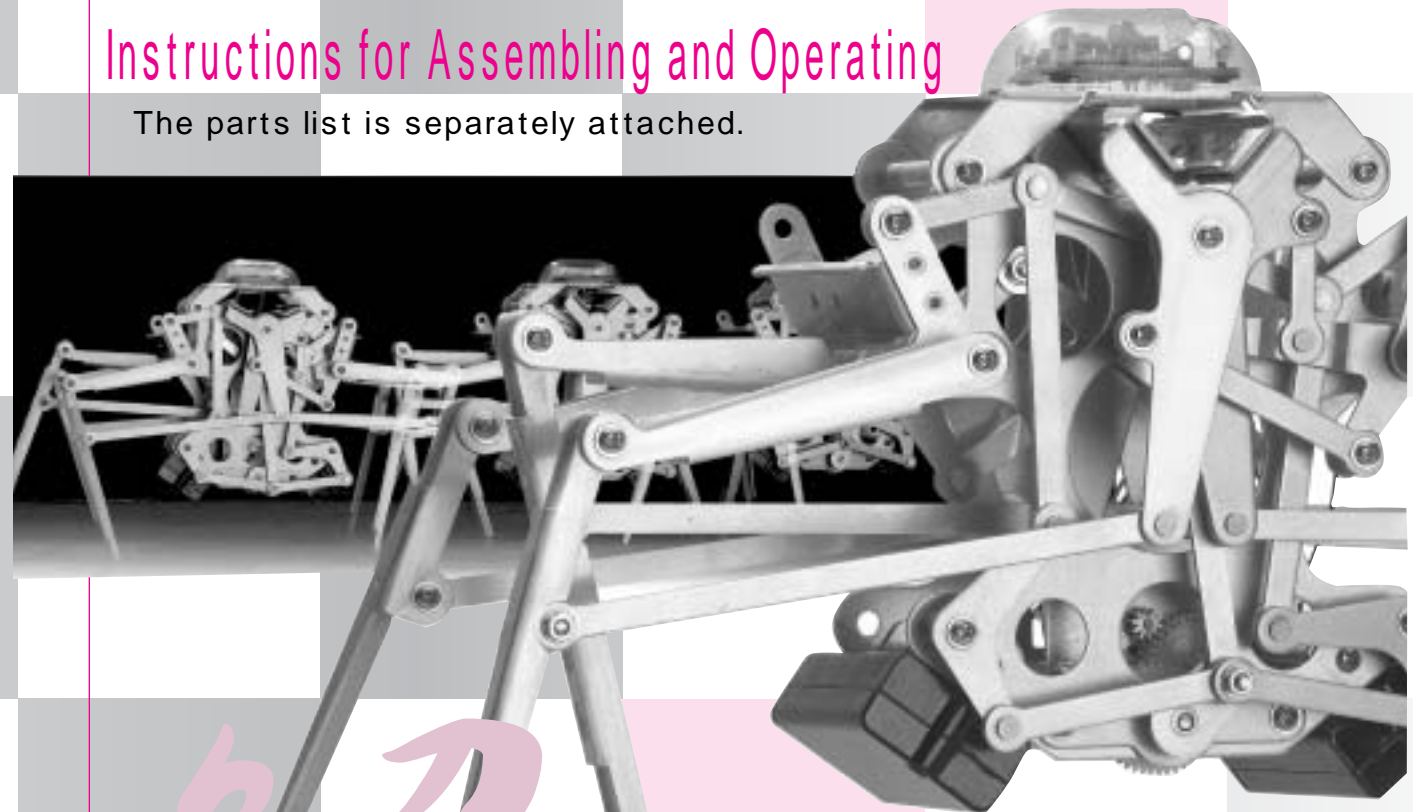

Gakken

角牛虫
Crab

CONTENTS

Contents and Cautions	2	2.Attaching Basic Leg Parts	7
The Animal-shaped Robot Devised from Mechanical Engineering "MECHAMO"	3	3.Attaching Upper Legs	9
1.Assembling the Center Part of the Main Body	4	4.Assembling Cranks	11
		5.Attaching Lower Legs	14
		Trouble Shooting	19

CAUTION! Please read the following instructions before using this kit.

Use caution when handling any metallic parts. Improper use may cause injury.
 To avoid the risk of suffocation, do not swallow small parts such as screws.
 To avoid the risk of injury, do not point your hands and eyes with the screwdriver and the like in this kit.
 To avoid the risk of injury, use caution not to get your fingers caught in the machine while it is operating.
 To avoid the risk of traffic accident, do not operate the machine on the road.
 To avoid the risk of electric shock, do not insert the lead wires into an electric socket.

Six size AA batteries are required. Improper use of the batteries may cause the generation of heat, explosions or leaks. The following precautions should be taken:

Do not use rechargeable batteries, such as nickel cadmium batteries.
 Ensure that the positive and negative terminals on the batteries are facing the right way.
 Do not use used batteries and new batteries together and do not mingle more than two kinds of batteries.
 Do not short-circuit, recharge, break up or put the batteries in a fire.
 Remove the batteries when not using for a long time.

Please read the assembly instructions and cautions in this booklet carefully before using this kit. Do not use any materials that have become damaged or deformed while in use.
 Keep the kit away from small children when not using.

Warning : Do not touch the Mechamo while it is operating. It is very dangerous. Particularly, never let small children touch it.

The metallic materials used in this kit
 main body parts : aluminum gear : sheet steel+brass screws : nickel-plated iron
 The plastic materials used in this kit
 battery box : ABS resin cover of the light sensor : ABS resin remote control : ABS resin
 connector : POM screwdriver handle : ABS resin
 * Vinyl chloride resin is used for the covers of the lead wires.
 * When disposing of the kit, please follow the recycling regulations in your area.

大人の科学 Otona no Kagaku

The Animal-shaped Robot Devised from Mechanical Engineering

MECHAMO
 メカモ
 Mechamo Crab
 THE MECHANICAL ANIMAL SERIES

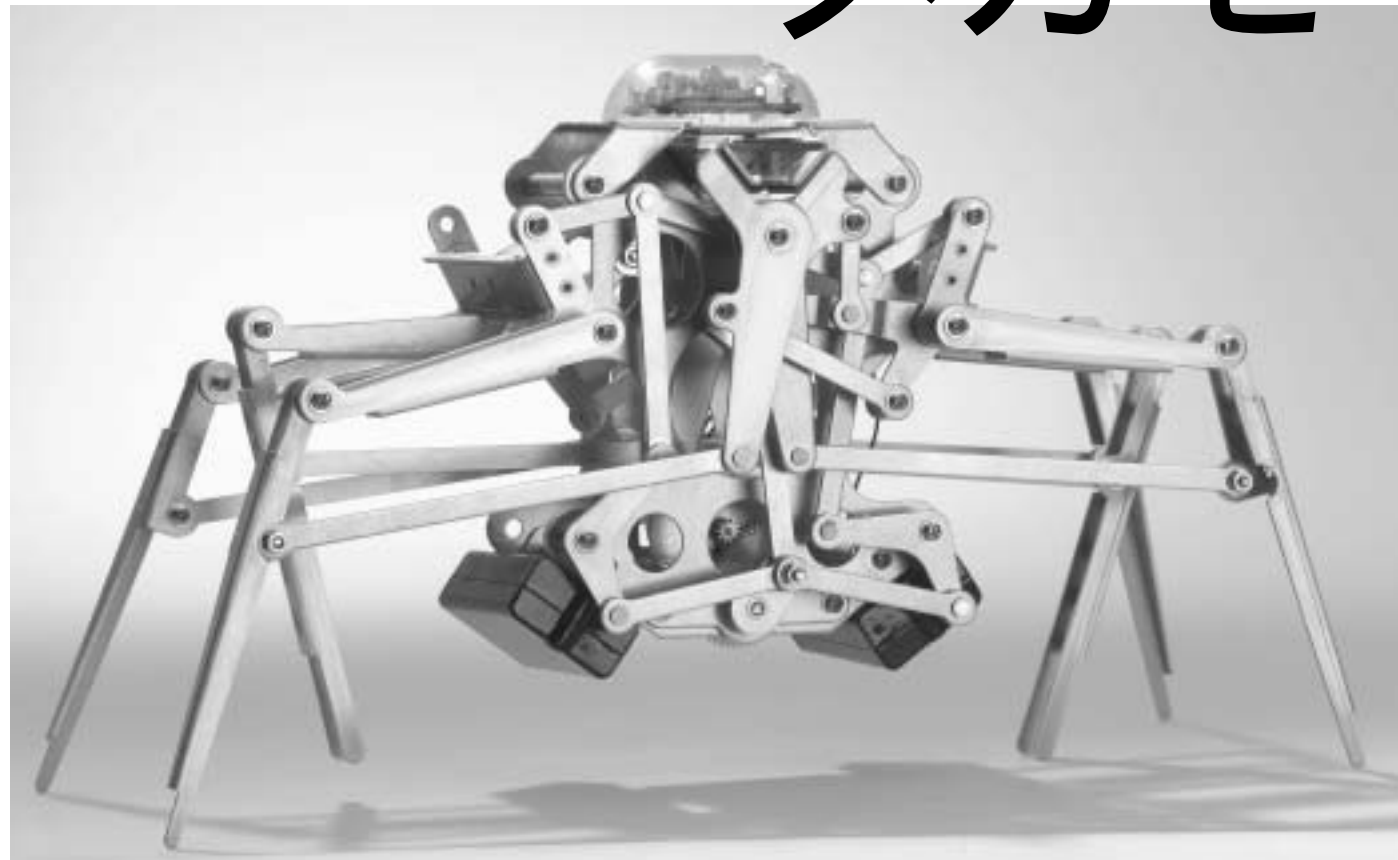

Among the Mechamo series robots, the mechanism of this Crab is the most complex one in which a variety of link mechanisms are installed. It moves in parallel without moving up and down and raises only the tips of legs to go over obstacles just like a crab. Enjoy assembling, examining from where to where the kinetic energy is transmitted through links and where the axis of the crank is located. Then, operating the machine will be more impressive. It takes about two hours to assemble. Please follow this instruction booklet when you assemble.

It will be helpful in assembling the kit if you set the parts list aside.

Warning Do not touch the Mechamo while it is operating. It is very dangerous. Particularly, never let small children touch it.

1 Assembling the Center Part of the Main Body



Let's assemble the center part of the main body first. Fasten the motor case and battery box holders to the main body with screws and nuts. The point is to tighten a screw while holding a nut with the wrench. When tightening from both sides with two screws, it is convenient to use the wrench as shown below.

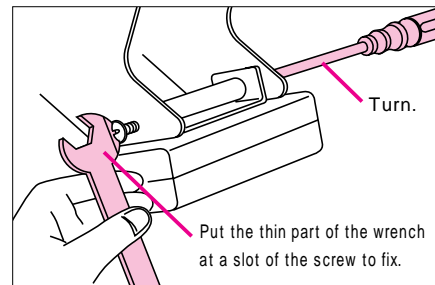

Supplied tools to be used

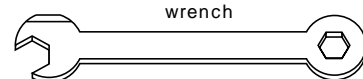
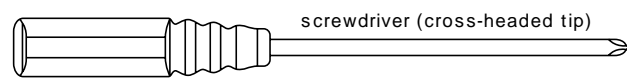

Parts to be used PARTS A There may be more screws, washers, nuts and bushes than actually used for spare.

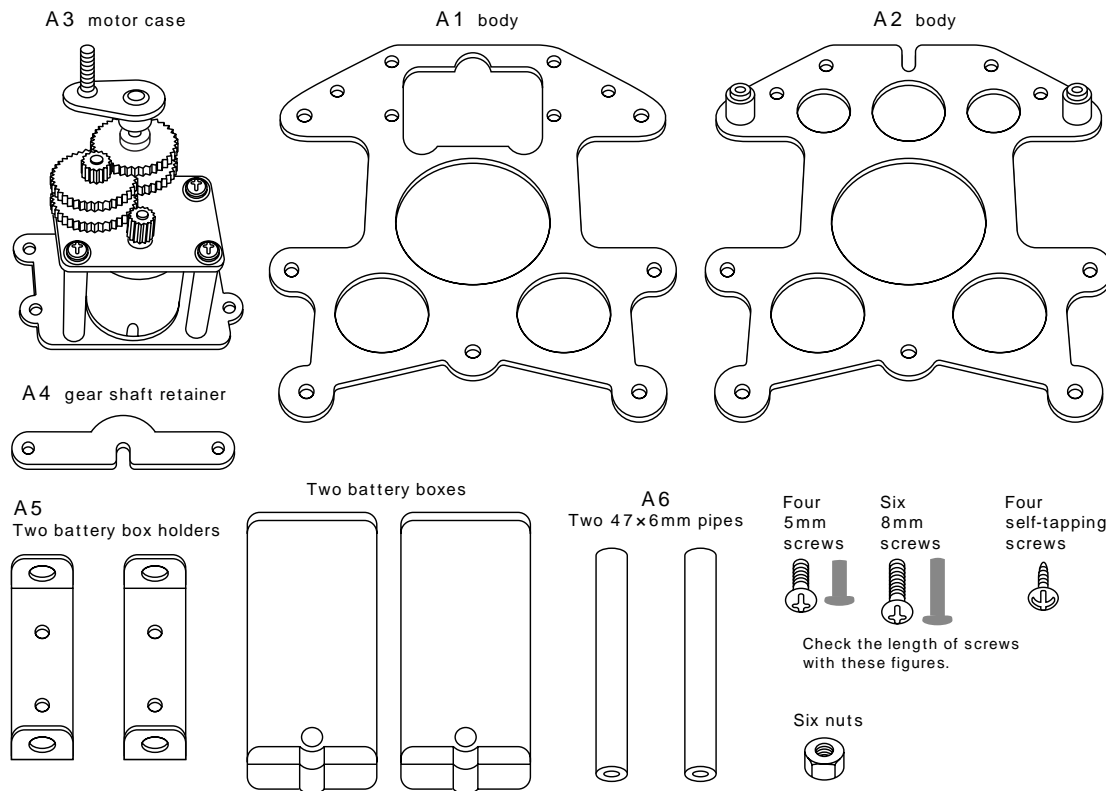

Figure-1 Set the motor case on the A1 body. Fasten at four points with screws and nuts tightly as shown in the figure.

1 Attach the motor case to the A1 body.

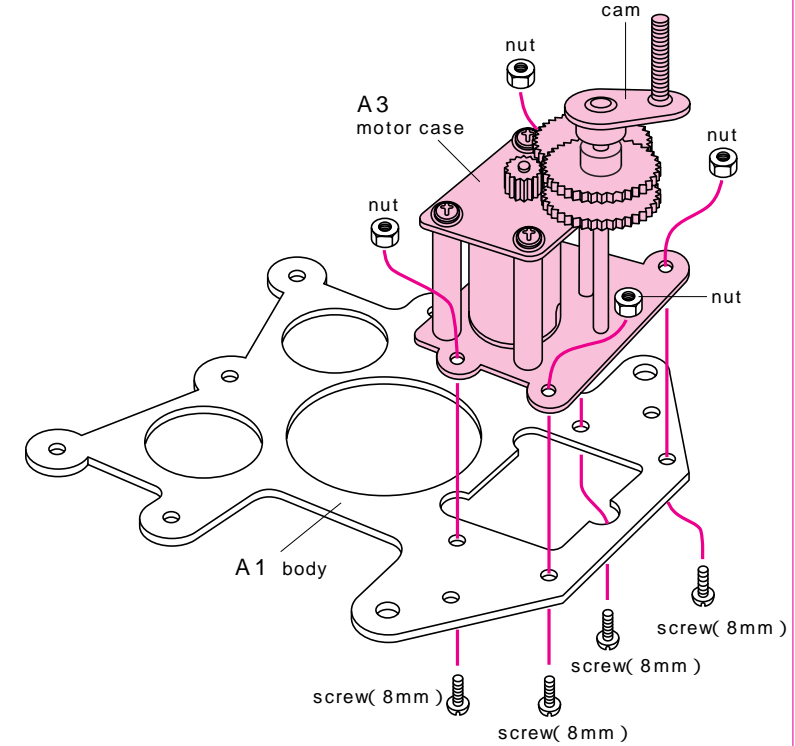
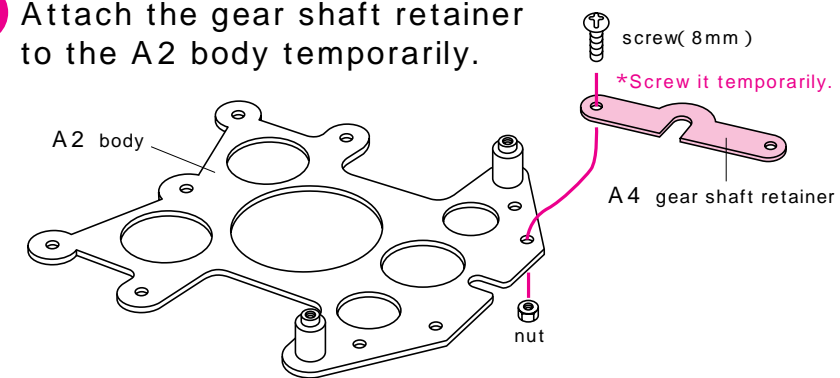

Figure-2 Attach the gear shaft retainer to the A2 body temporarily.

2 Attach the gear shaft retainer to the A2 body temporarily.



Notice
The motor case is pre-assembled but if it comes apart, assemble as shown in the figure.

Put the bushes on the gear shafts and put them in the motor case.

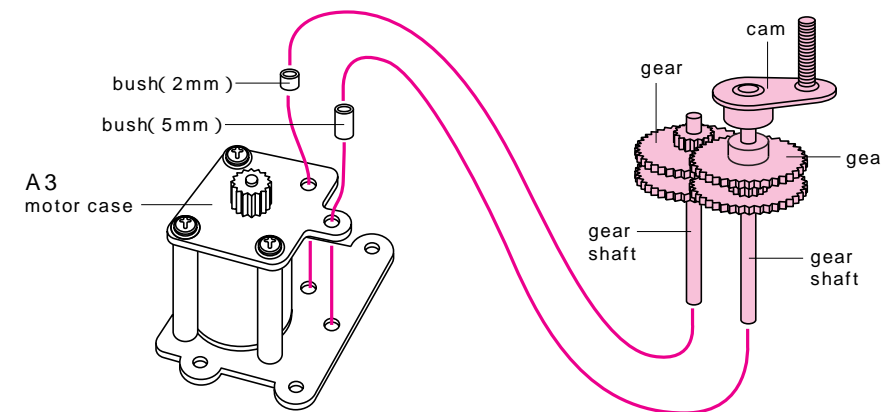

Warning Do not touch the Mechamo while it is operating. It is very dangerous. Particularly, never let small children touch it.

Figure—3
Set the gear shaft into the notch of the A2 body and turn A4 to the direction of the arrow in the figure and fasten the end with a screw and a nut.
Fasten both ends of the gear shaft retainer completely to the A2 body with specified screws and nuts.

Notice
From now on, the part with the cam is described as the front part and the part with cords is described as the back part.

Figure—4
Attach battery box holders to the battery boxes. Then attach the boxes to the body.

Attach battery box holders to the battery boxes.

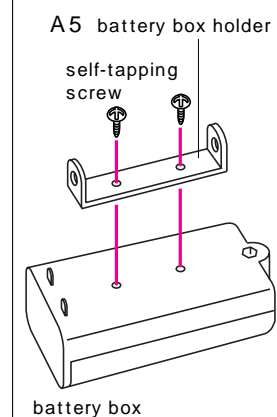

Full-scale *Check the size with this.
A6 pipe(47×6mm X 2)

3 Combine the A1 body and the A2 body.

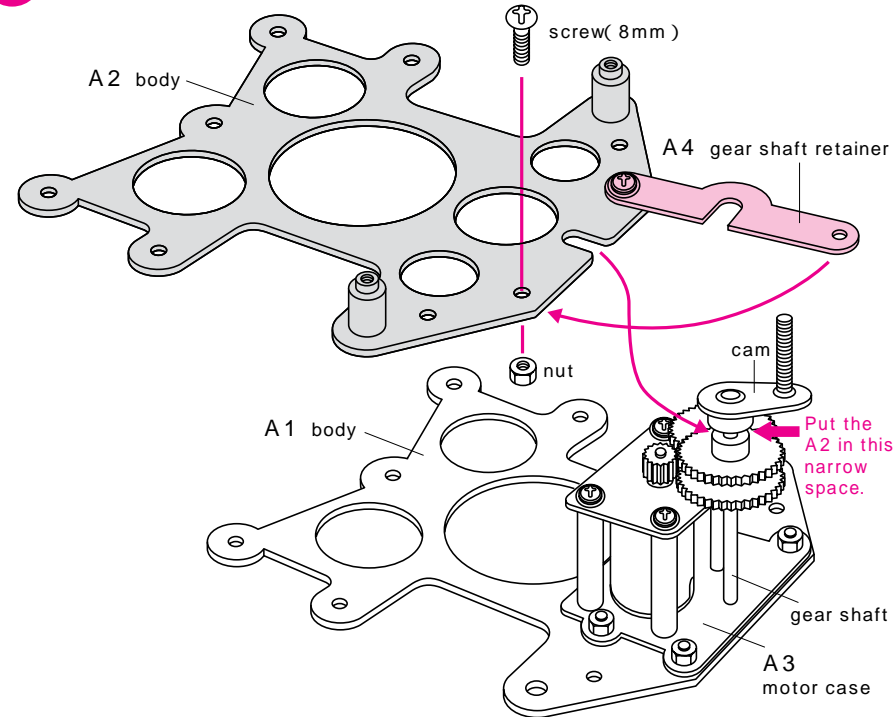

4 Attach battery boxes to the body.

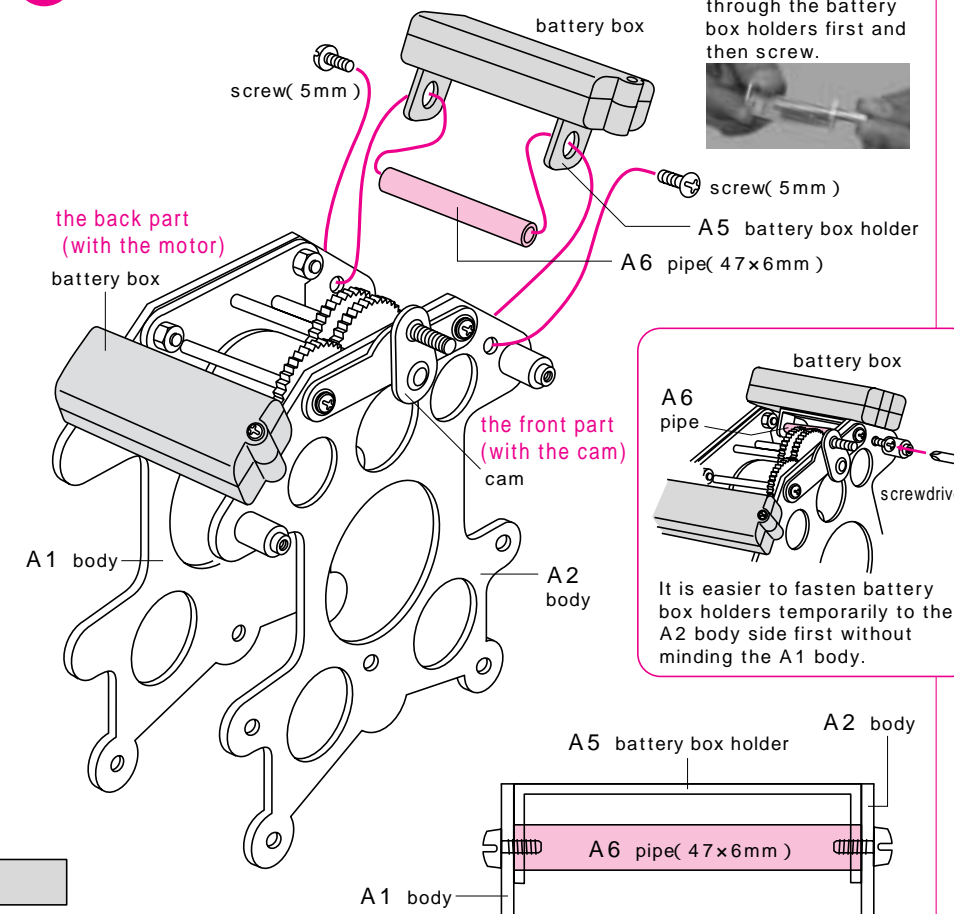

2 Attaching Basic Leg Parts

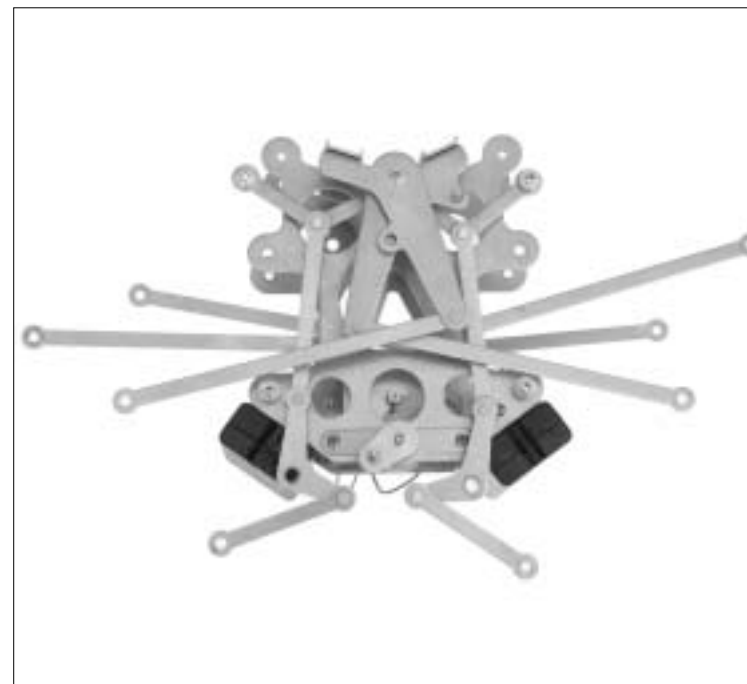

Let's attach basic leg parts to the body. Check each figure well and fasten with screws after confirming in which direction each arm and crank is attached. (If each direction is not right, the machine doesn't work well.) Particularly, pay attention not to mistake B3 for B4 because they are very alike. (They can be distinguished by the difference of the heights of bushes with collar.)

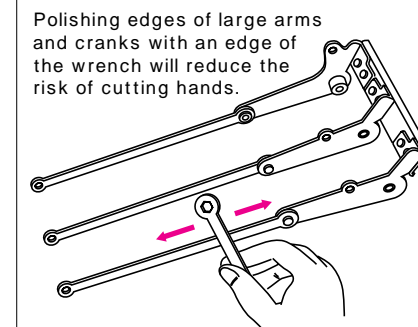

Parts to be used PARTS B

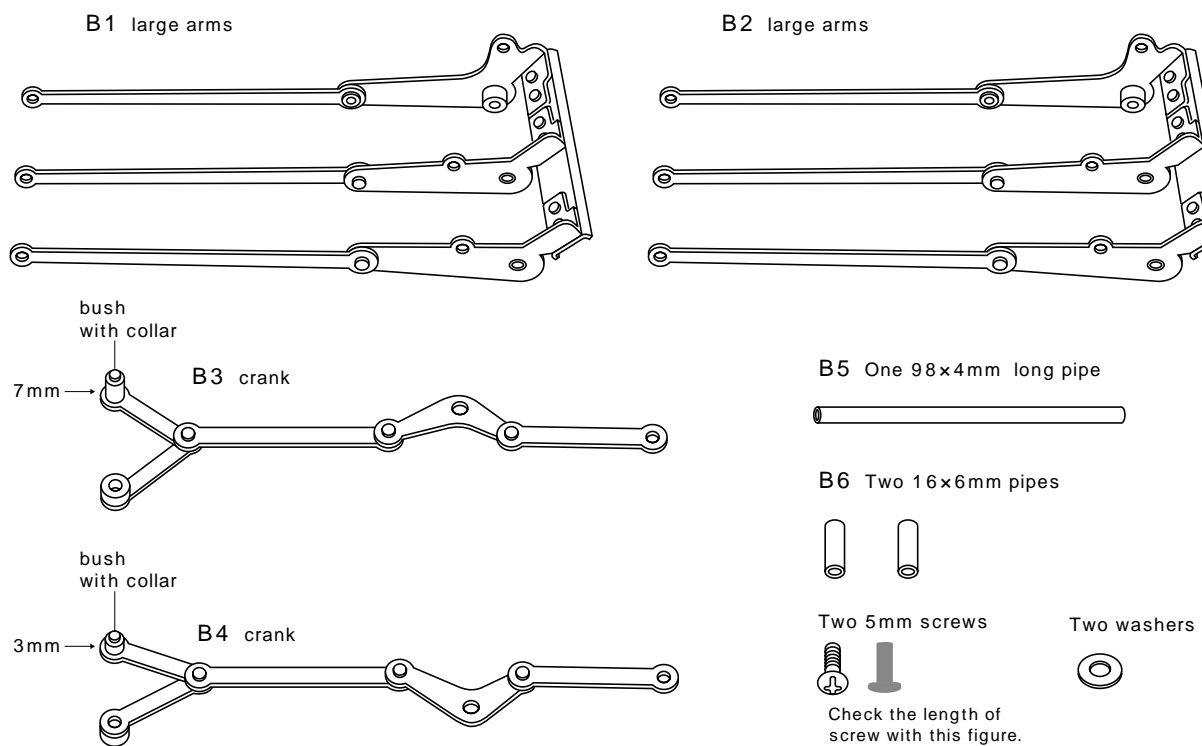

Warning Do not touch the Mechamo while it is operating. It is very dangerous. Particularly, never let small children touch it.

Figure—5
Stretch out the center one of three connected arms of B1 large arms to the opposite side and put it on the body.

Similarly, stretch the center one of the B2 large arms to the opposite side and put it on the body.

5 Assembling the basic leg parts.

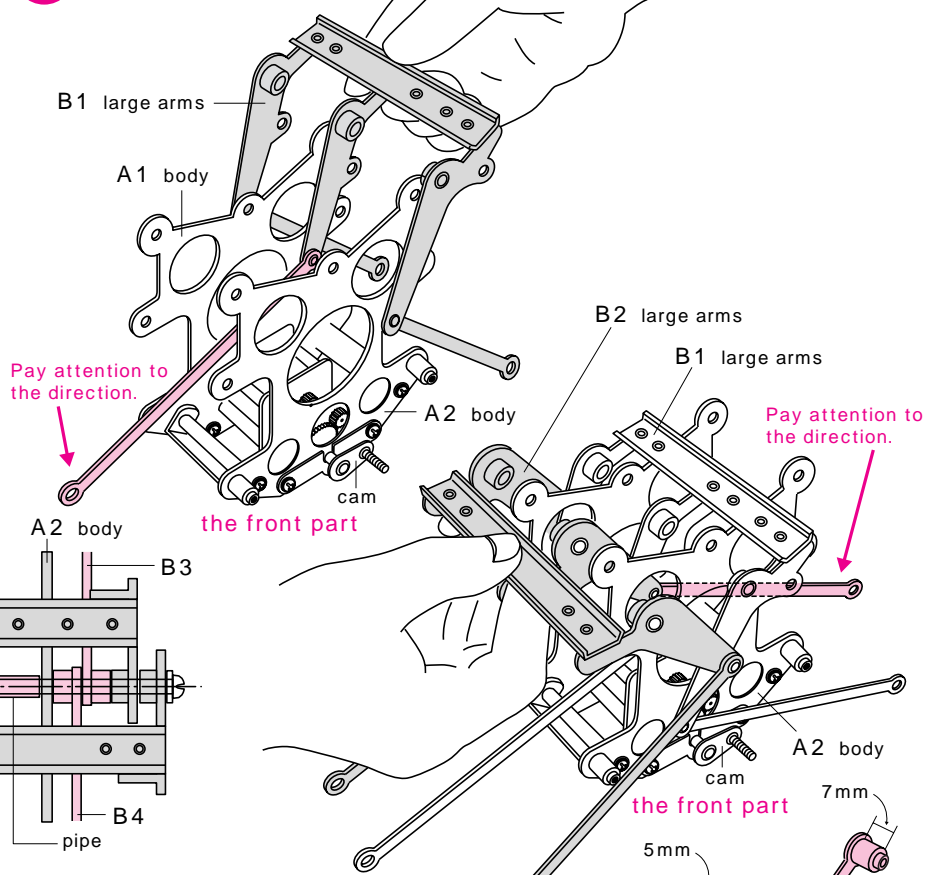

Figure—6
Connect two cranks to B1 and B2 large arms with a long pipe. Fasten them with screws firmly as shown in the figure. (Be careful not to cross the red parts of B4 and B3 in the figure below.)

6 Attaching cranks.

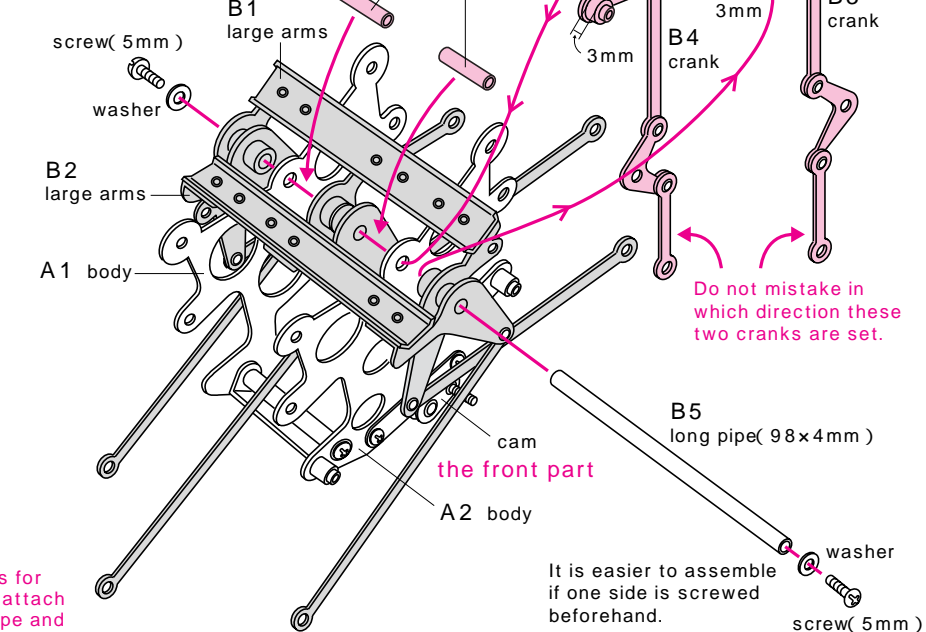

Full-scale *Check the size with this.

B6 pipe(16x6mm X 2)

Choose B6 pipes for sure before you attach because a B6 pipe and a C8 pipe are very alike.

B5 long pipe(98x4mm)

It is easier to assemble if one side is screwed beforehand.

3 Attaching Upper Legs

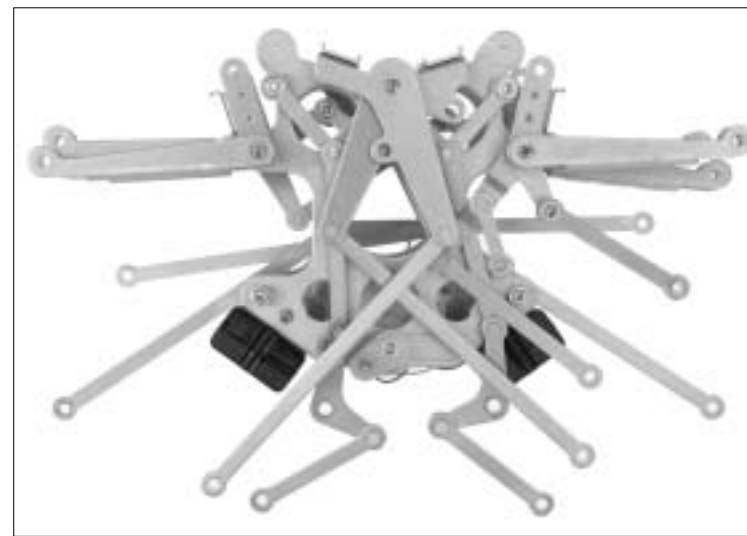

Let's attach upper legs (thigh parts if it is a human) to the body. Look at figures well and confirm the front and the back while assembling. Pay special attention to the positions where C5 and C6 links and C3 and C4 upper center legs are attached. Don't forget to attach bushes at Figure—8. If you do, the machine does not move smoothly when it is complete.

Parts to be used PARTS C

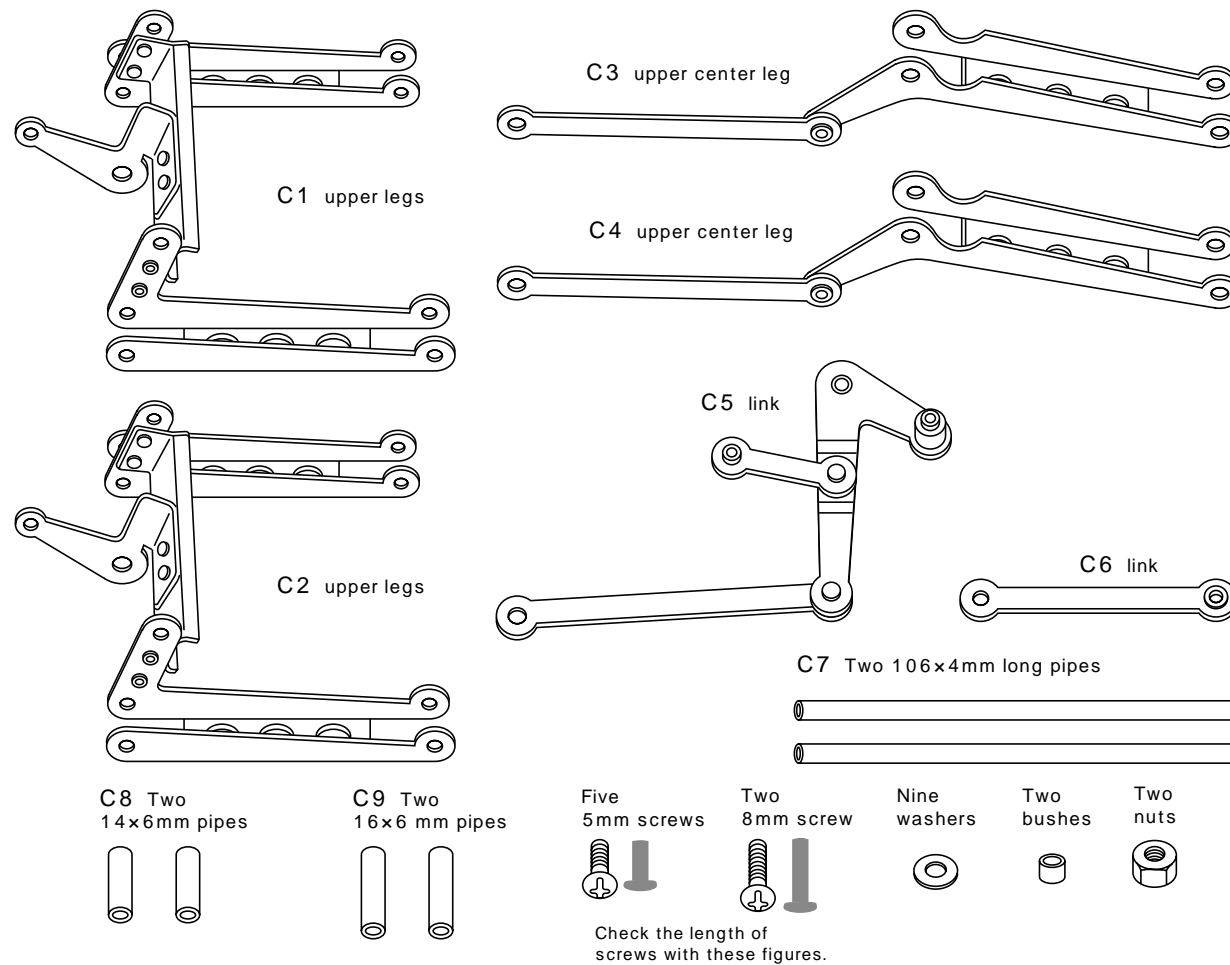

Warning Do not touch the Mechamo while it is operating. It is very dangerous. Particularly, never let small children touch it.

Figure—7
Attach C1 and C2 upper legs and C3 and C4 upper center legs to the body by putting through long pipes and screwing. Put pipes in between.

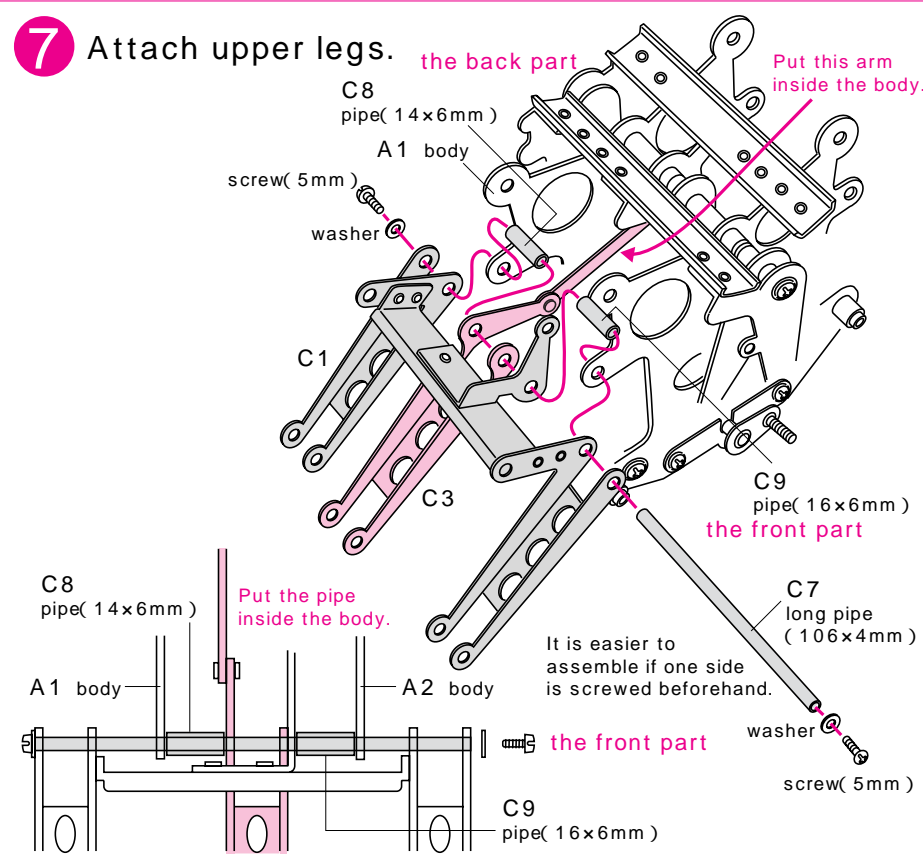

Full-scale *Check the size with this.
C7 long pipe(106×4mm)

- C8 pipe(14×6mm)
- C9 pipe(16×6mm)

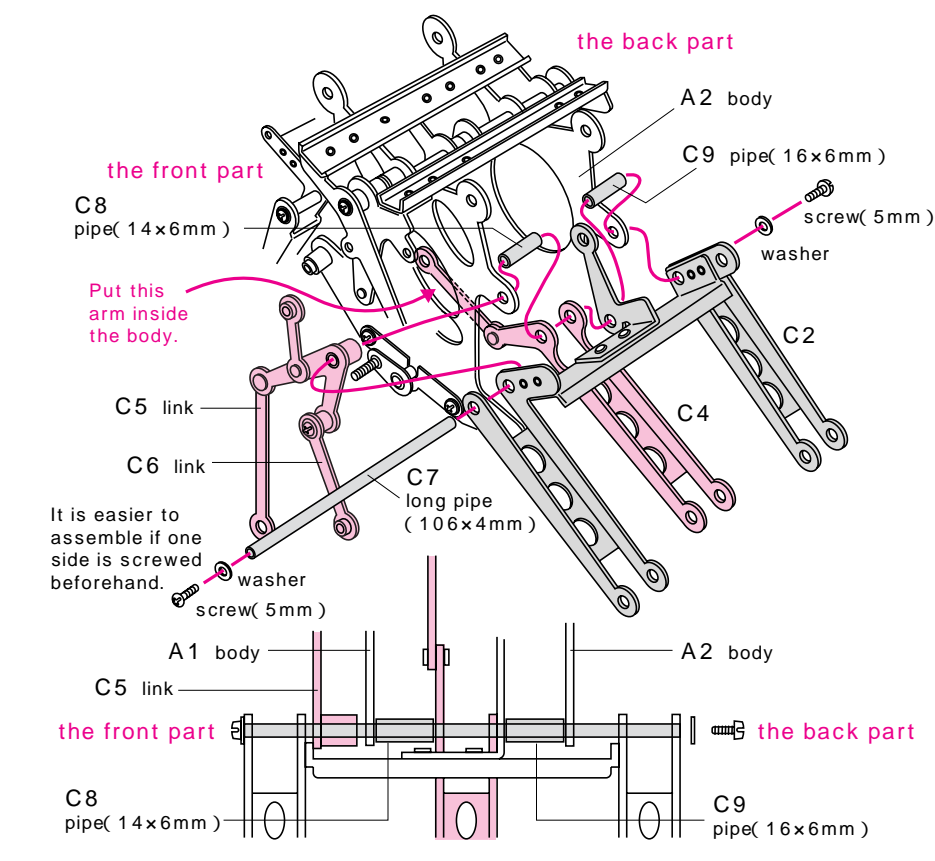
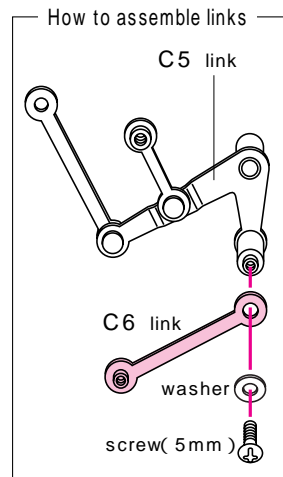

Figure—8
Connect each arm of C3 and C4 upper center legs as shown in the figure.

Notice
Don't forget to add bushes at this process.

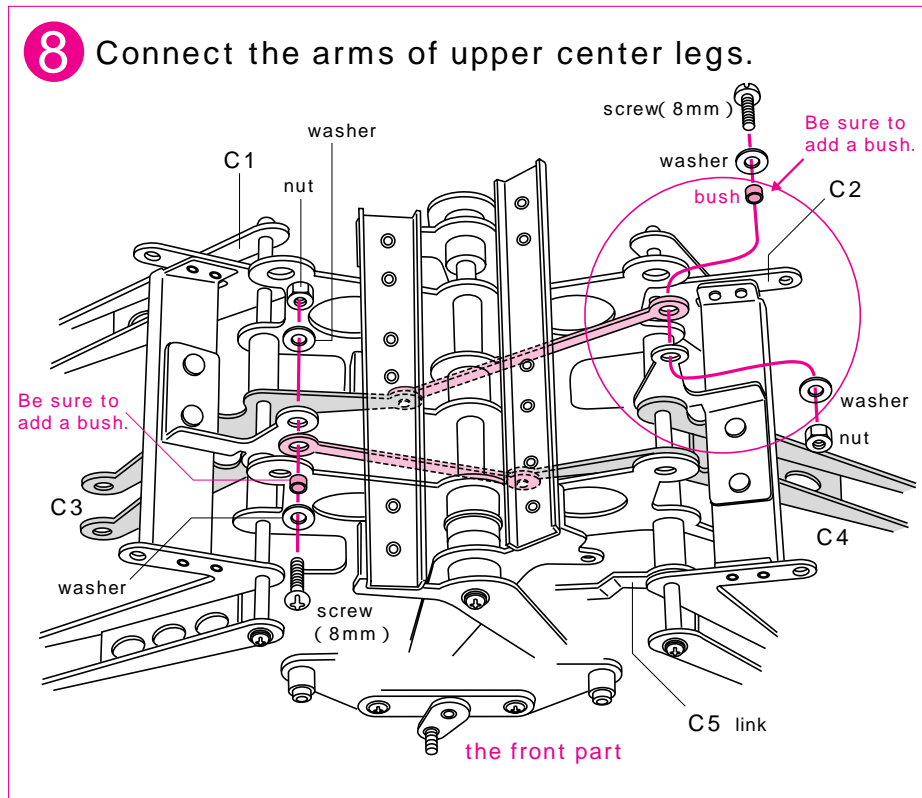
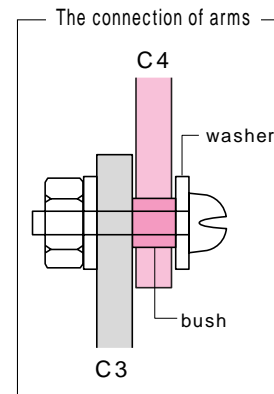

4 Assembling Cranks



Let's connect cranks and links. Look at figures carefully to check which part is connected to which part before assembling. Particularly, pay attention to the order of parts at Figure—12.

Parts to be used PARTS

- Six 5mm screw
 - Ten washers
 - One nut
 - Three bushes
- Check the size with this figure.

Warning Do not touch the Mechamo while it is operating. It is very dangerous. Particularly, never let small children touch it.

Figure—9
Fasten the bush with collar of the B4 crank attached at Figure—6 to the upper legs assembled at Figure—7 with a screw. At the right side, fasten the B3 crank in the same way.

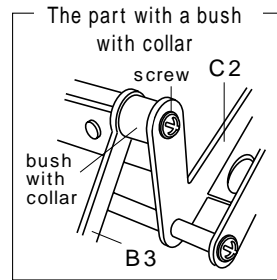

Figure—10
Connect the C5 link attached at Figure—7 to B1 large arms, and C6 to B2 large arms.



Figure—11
Connect the B4 crank attached at Figure—6 to the bush with collar of the A2 body. At the right side, connect the B3 crank in the same way.

9 Connect cranks to upper legs.

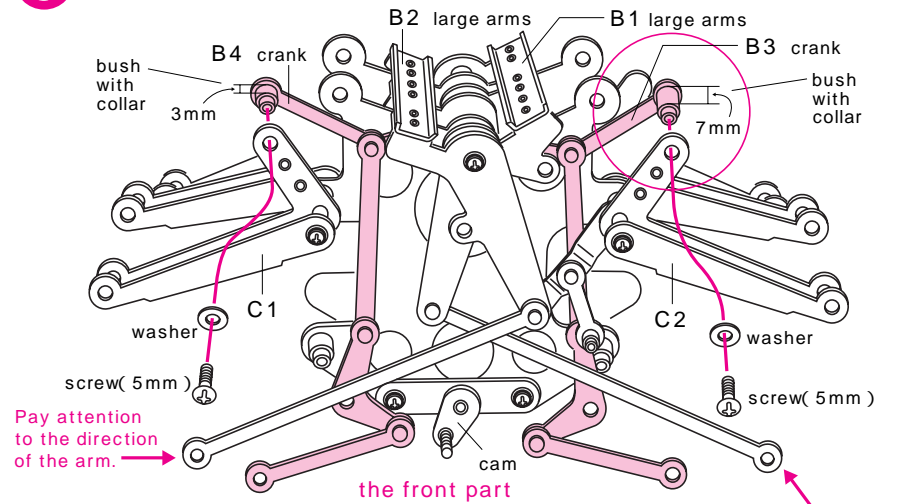

10 Connect links to large arms.

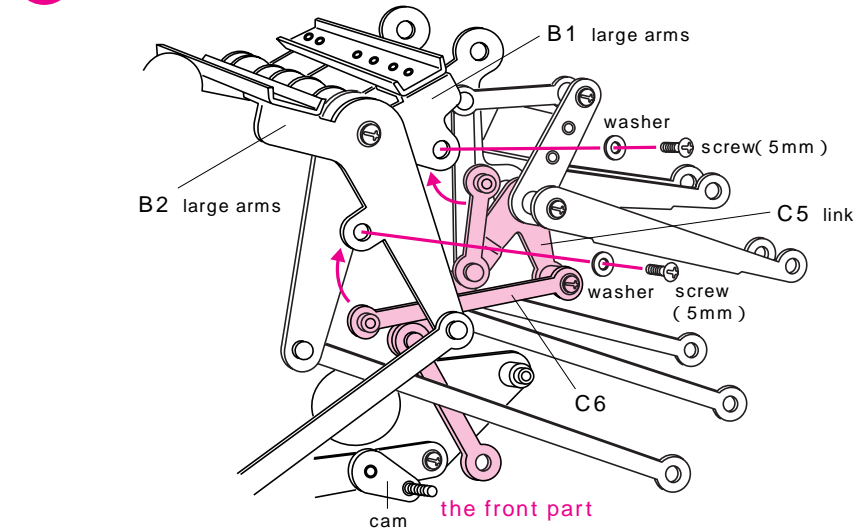

11 Connect cranks to the body.

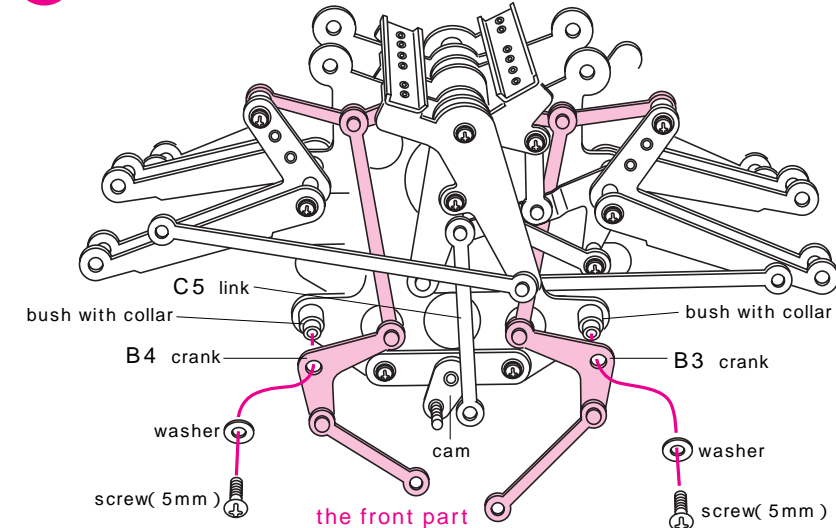

Figure—12
Connect the C5 link and B3 and B4 cranks to the cam.

Notice
Attach the parts in the following order.
cam
washer
bush
C5 link
washer
bush
B4 crank
washer
bush
B3 crank
washer
nut

If it is difficult to put links and cranks on the shaft of the cam, turn wheels and adjust the position of the cam.

Fit each bush into each hole in a link or crank first, and then fasten with a nut. (Three bushes are used.)

Make sure that a bush fits in the hole in the C5 crank.

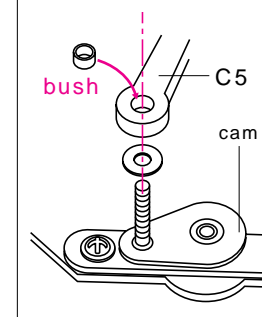

12 Connect links and cranks to the cam.

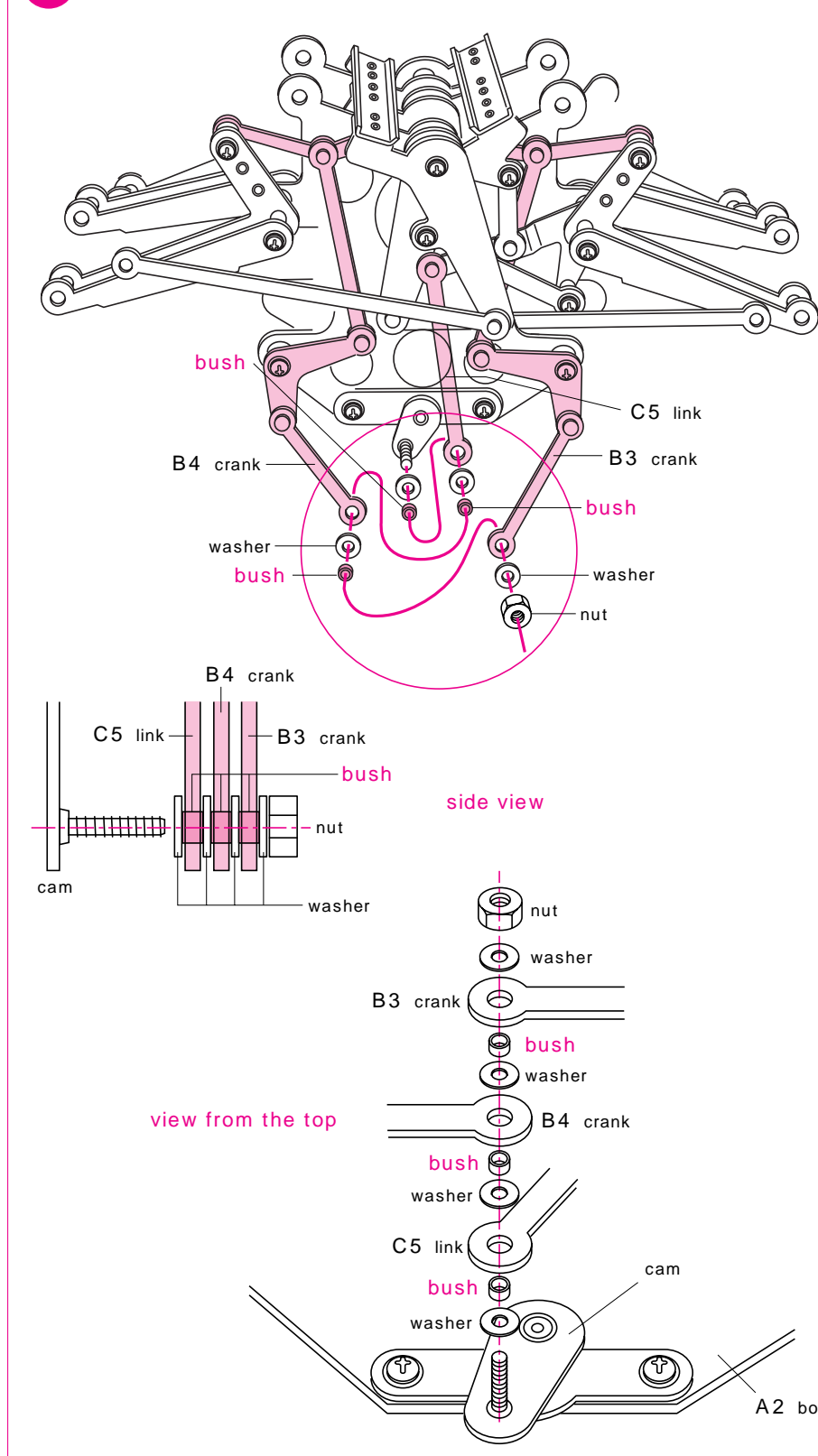

Warning Do not touch the Mechamo while it is operating. It is very dangerous. Particularly, never let small children touch it.

5 Attaching Lower Legs



Let's attach six lower legs to upper legs one by one. Pay attention to directions of six lower legs when they are connected to arms in the middle. (Look at figures carefully and keep the front and the back in mind.) Also, don't forget to put in bushes.

Next, let's put batteries in battery boxes. (Two size AA dry batteries each. Four in all.) Finally, wire battery boxes to the light sensor, and the motor to the light sensor, and set the sensor in sensor holders.

Parts to be used PARTS D

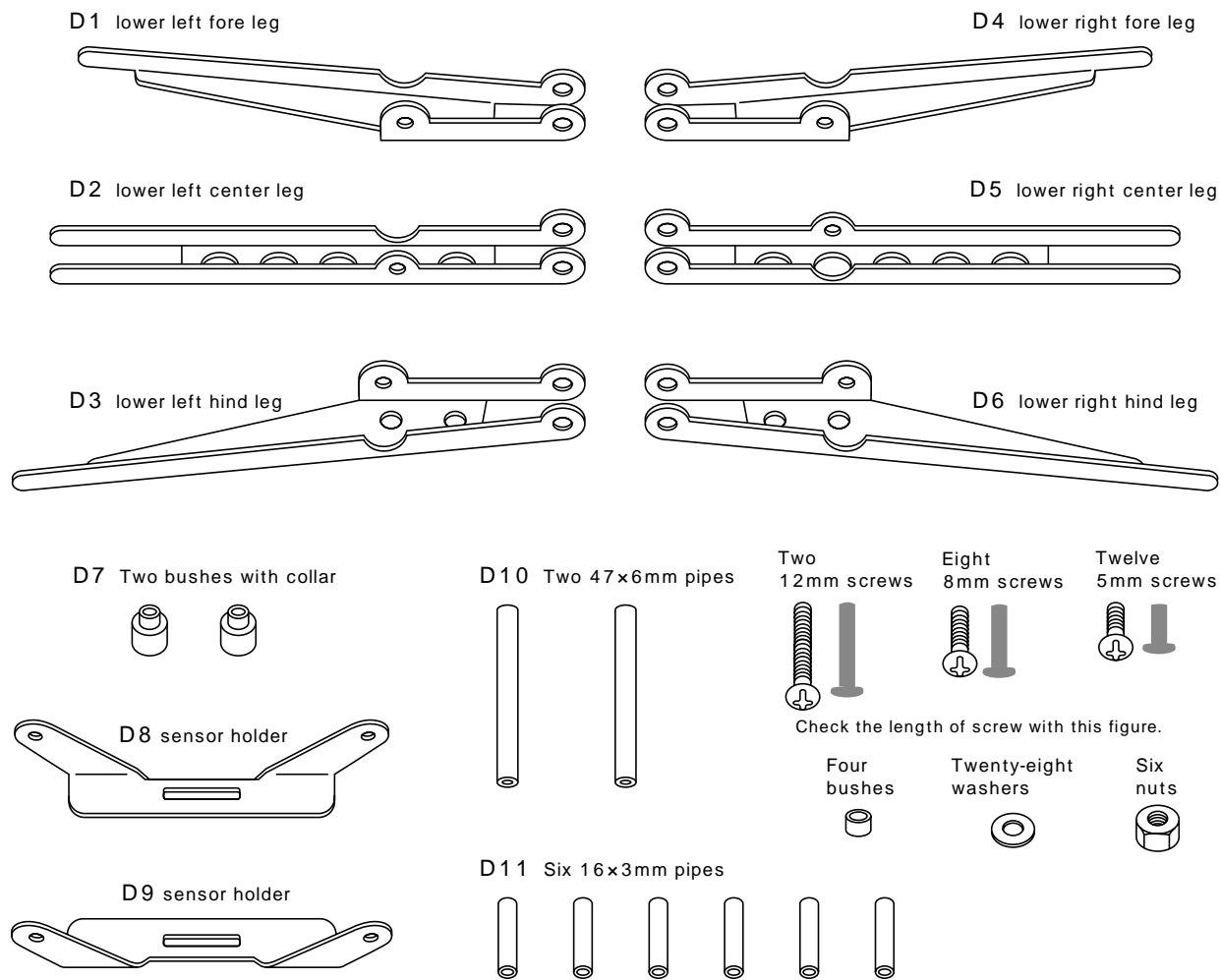

Figure—13
Look at D1 at upper left in the figure. When attaching the D1 lower left fore leg to a B2 arm, don't forget to add a bush with collar.

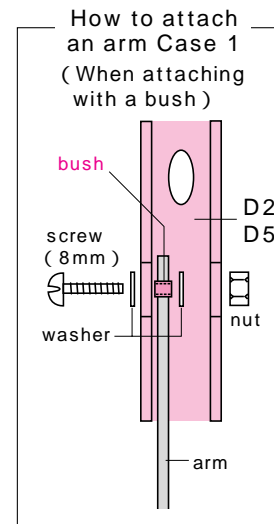

Figure—14
Look at D6 at lower right in the figure. When attaching the D6 lower right hind leg to a B1 arm, don't forget to add a bush with collar.

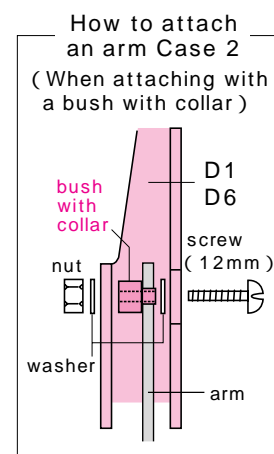

13 Attach lower left legs.

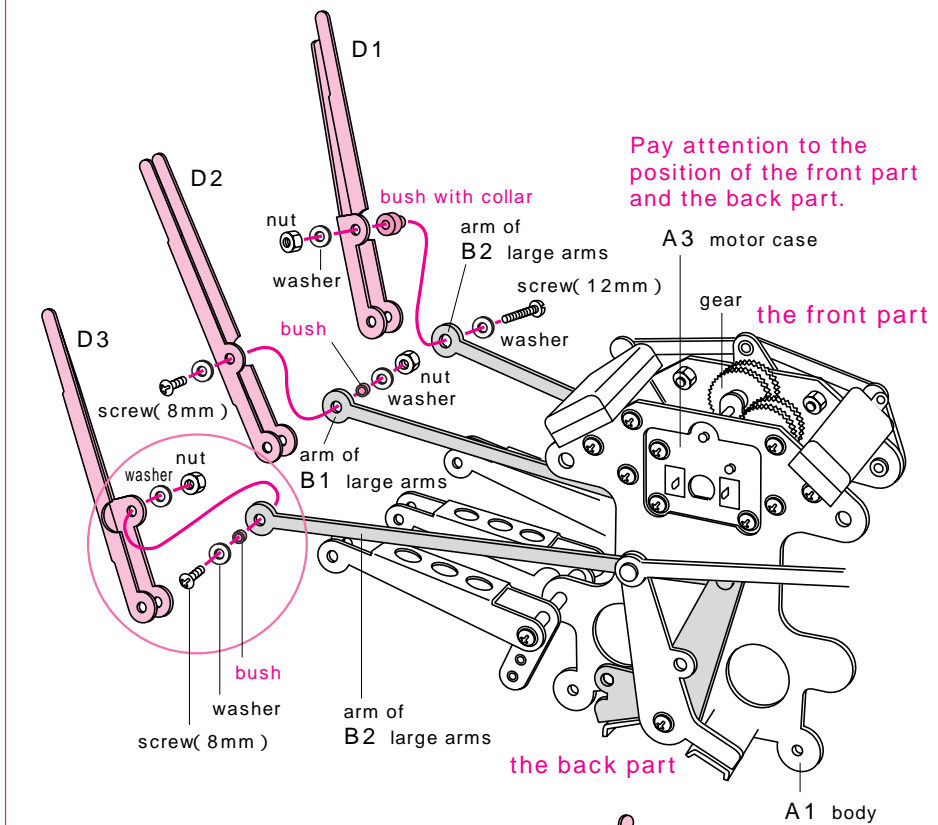

14 Attach lower right legs.

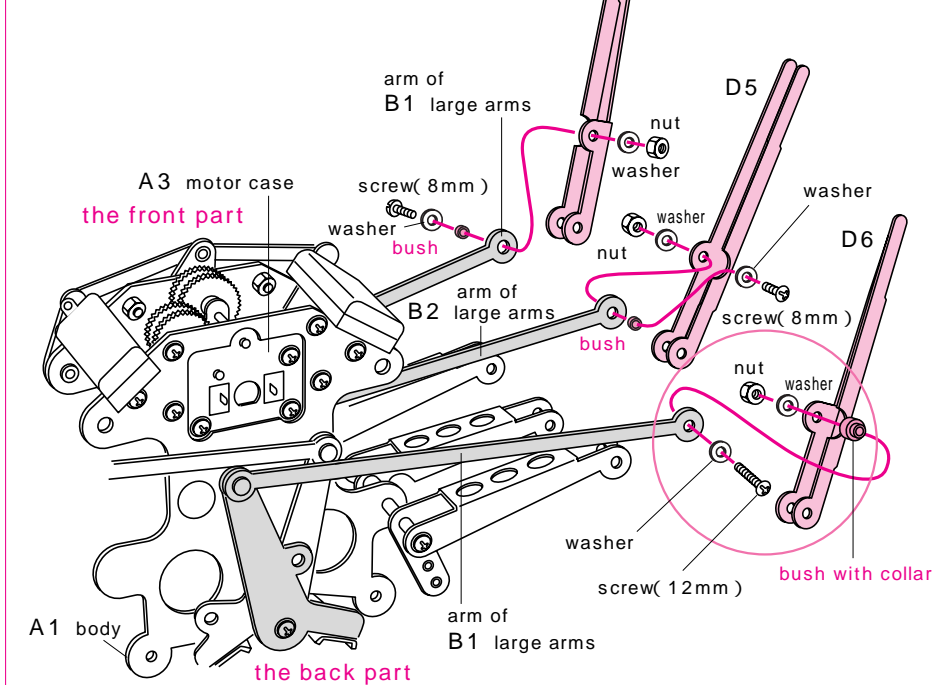

Warning Do not touch the Mechamo while it is operating. It is very dangerous. Particularly, never let small children touch it.

Figure—15
Fasten lower legs to upper legs with pipes and screws. Fasten all of the six right and left legs.

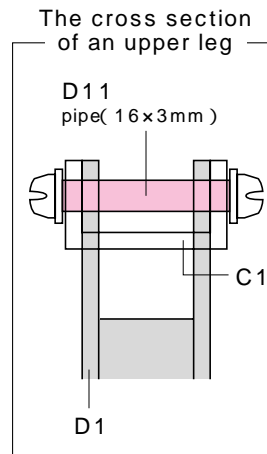

15 Connect upper legs.

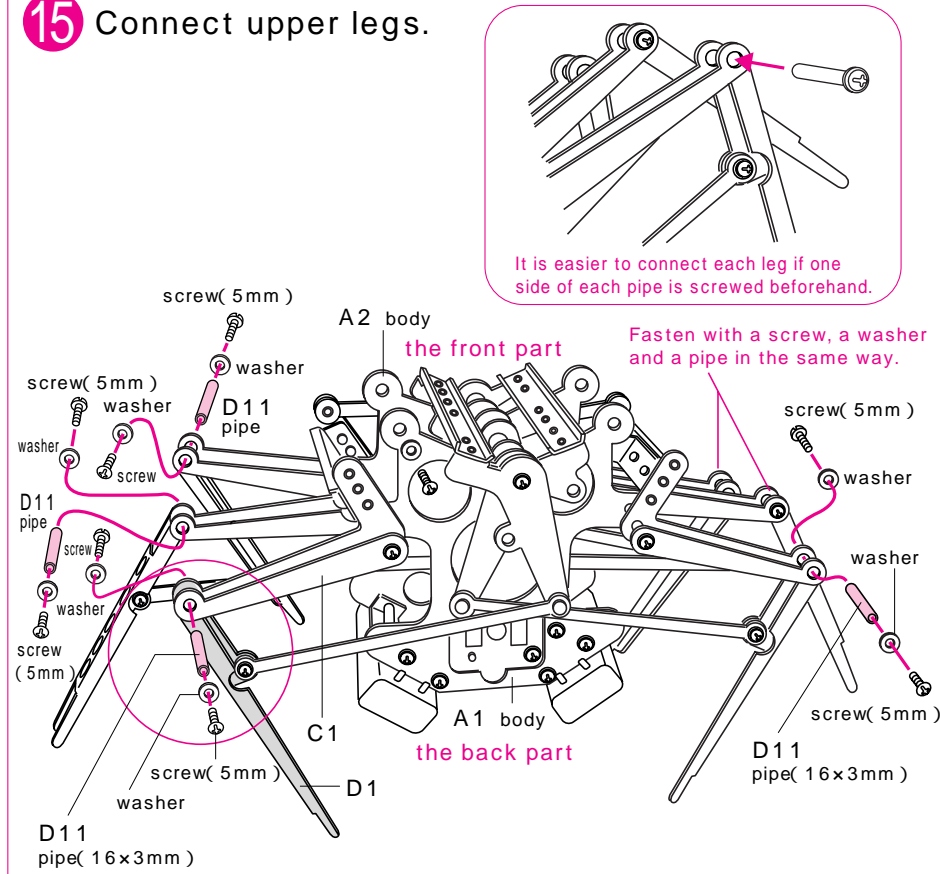

Figure—16
Put D10 pipes through D8 and D9 sensor holders, and set them between A1 and A2 bodies and fasten with screws.

16 Attach sensor holders.

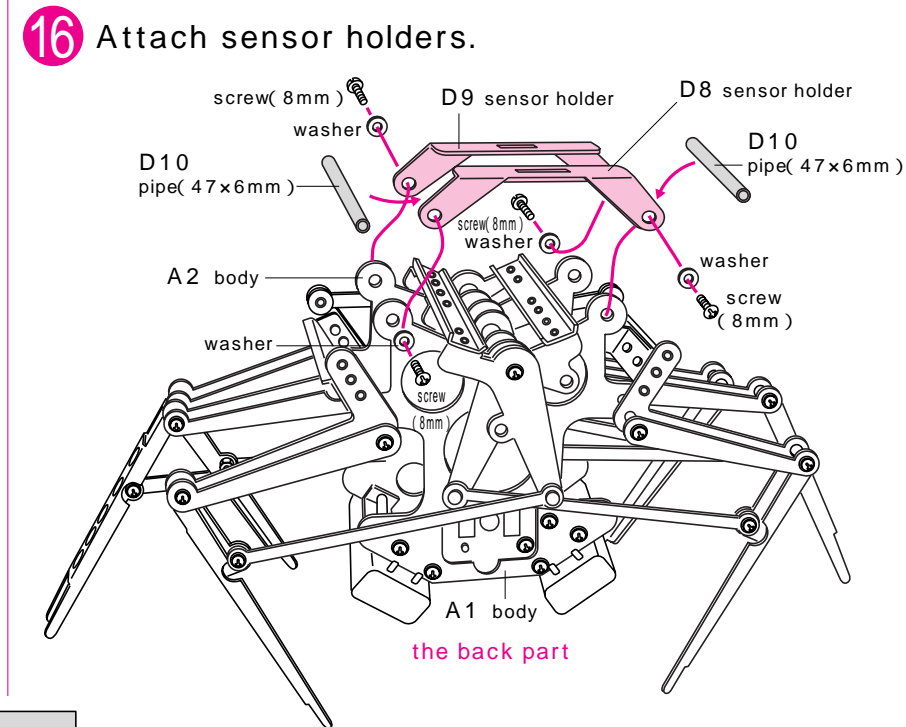

Full-scale *Check the size with this.
D10 pipe(47×6mm X 2)

Figure—17
Join connectors of lead wires coming from battery boxes and from the motor to those coming from the light sensor. Wire the lead wires as shown in the figure. (The lead wires from battery boxes are red and black and those from the motor are blue and yellow.)

17 Connect battery boxes, the motor and the light sensor with lead wires.

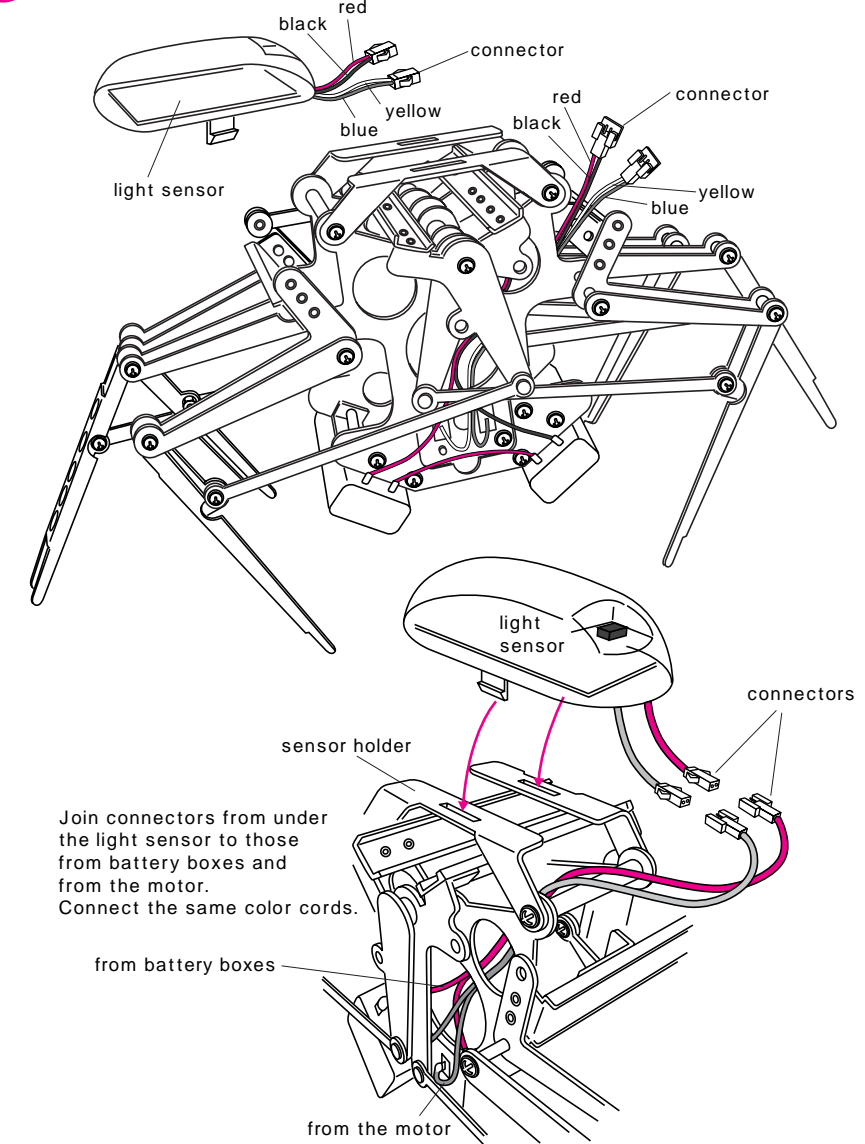

Figure—18
Set the wired light sensor on the sensor holders. Insert pins into holes.

18 Install the light sensor.

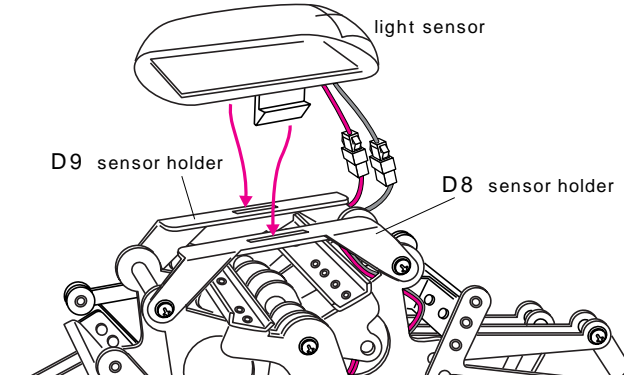

Warning Do not touch the Mechamo while it is operating. It is very dangerous. Particularly, never let small children touch it.

Figure—19
You've finished the assembly.

19 Now the Mechamo crab is complete!
View from the Front Part

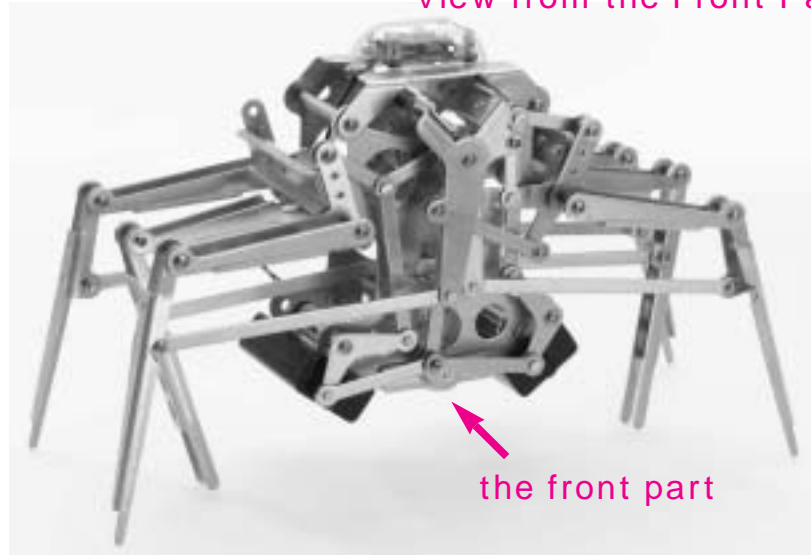

View from the Back Part

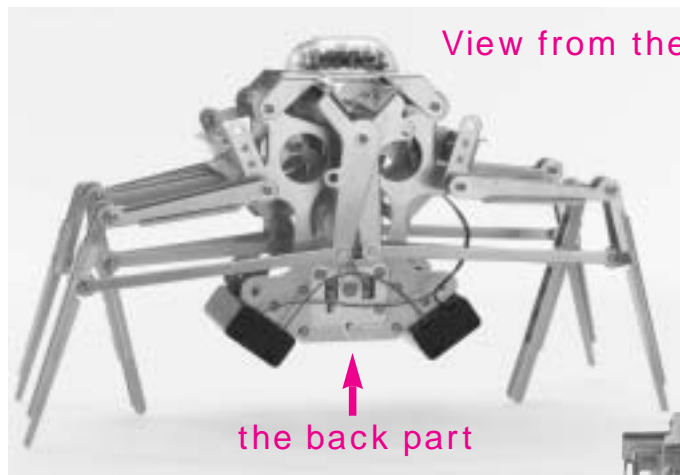

Side View

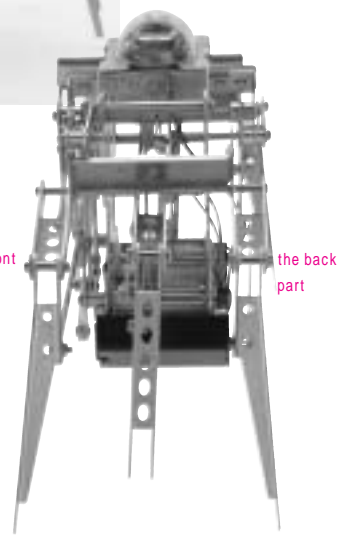

20 How to hold the crab.

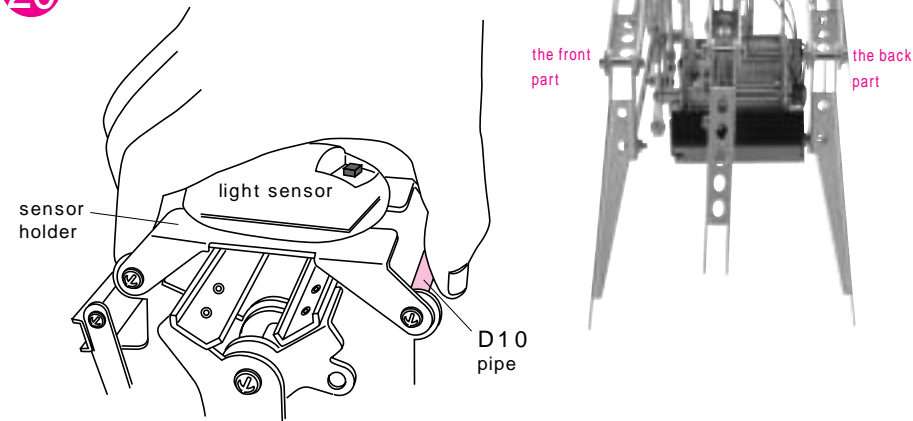

How to change batteries in a battery box
Loosen the screw with a screwdriver and open the lid. Set batteries in the right way and screw the lid.

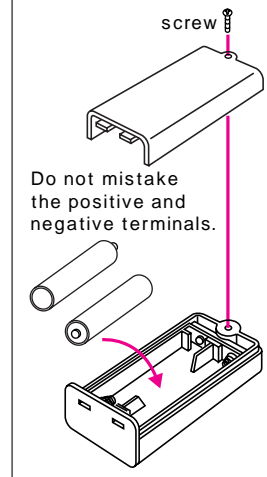

Remove the batteries when not using the machine for a long time.

Figure—20
Be sure to hold only D10 pipes when carrying. Do not hold other parts. When switching off the sensor, be sure to hold only D10 pipes as well. It is very dangerous if fingers are caught in operating parts. Particularly, never let small children touch the machine.

Warning Do not touch the Mechamo while it is operating. It is very dangerous. Particularly, never let small children touch it.

Figure—21
First, turn on the switch of the light sensor. Then, you can handle the machine with the remote control.

How to change batteries in the remote control

Loosen the screw with a screwdriver and open the lid. Set batteries in the right way and screw the lid.

Do not mistake the positive and negative terminals.

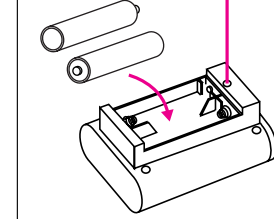

21 How to operate.(How to use the remote control)

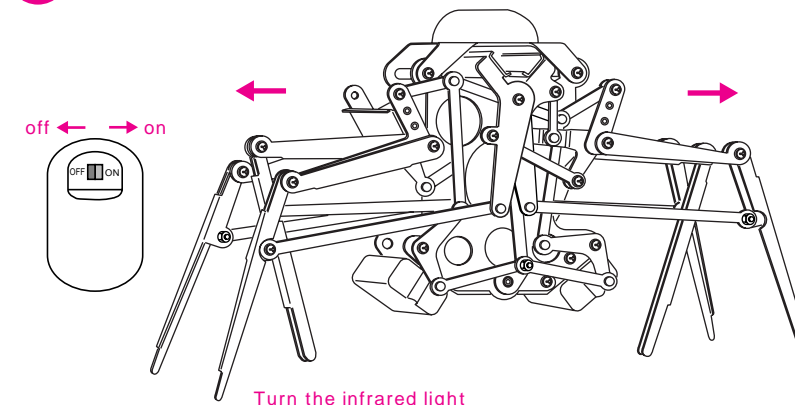

Turn the infrared light emitter to the light sensor and move the control stick to right and left, and the Mechamo moves to right and left.

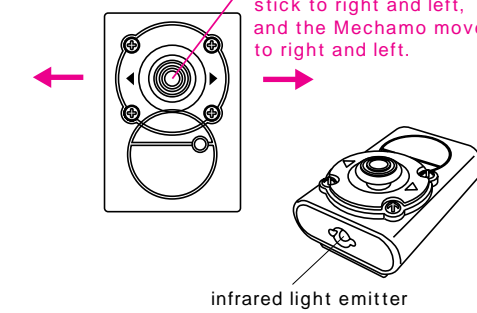

Hold D10 pipes when turning on and off the switch of the light sensor.

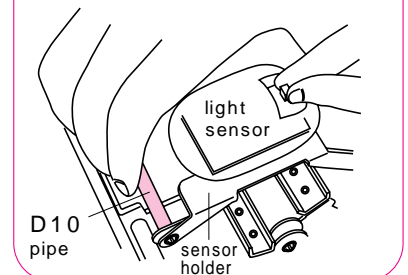

Warning : Never touch the Mechamo while it is operating. Be sure to stop the Mechamo with the remote control and turn off the switch of the light sensor before you touch. Touching the operating Mechamo may cause injury to your fingers.

Trouble Shooting MECHAMO

Q : The Mechamo doesn't react to the control stick.

A : Check the following points.

1. Have you turned on the switch of the light sensor?
2. Are the six batteries new? (four for the motor and two for the remote control)
3. Have you wired battery boxes, the motor and the light sensor correctly?

Q : The Mechamo reacts to the control stick but doesn't start moving.

A : Check the following points.

1. Have you tightened every screw?
2. Have you assembled correctly? (Check the machine with the picture of the finished Mechamo at p.18.)
3. Have you put all the bushes? (See p.11, p.13 and p.15 and check the bushes.)